

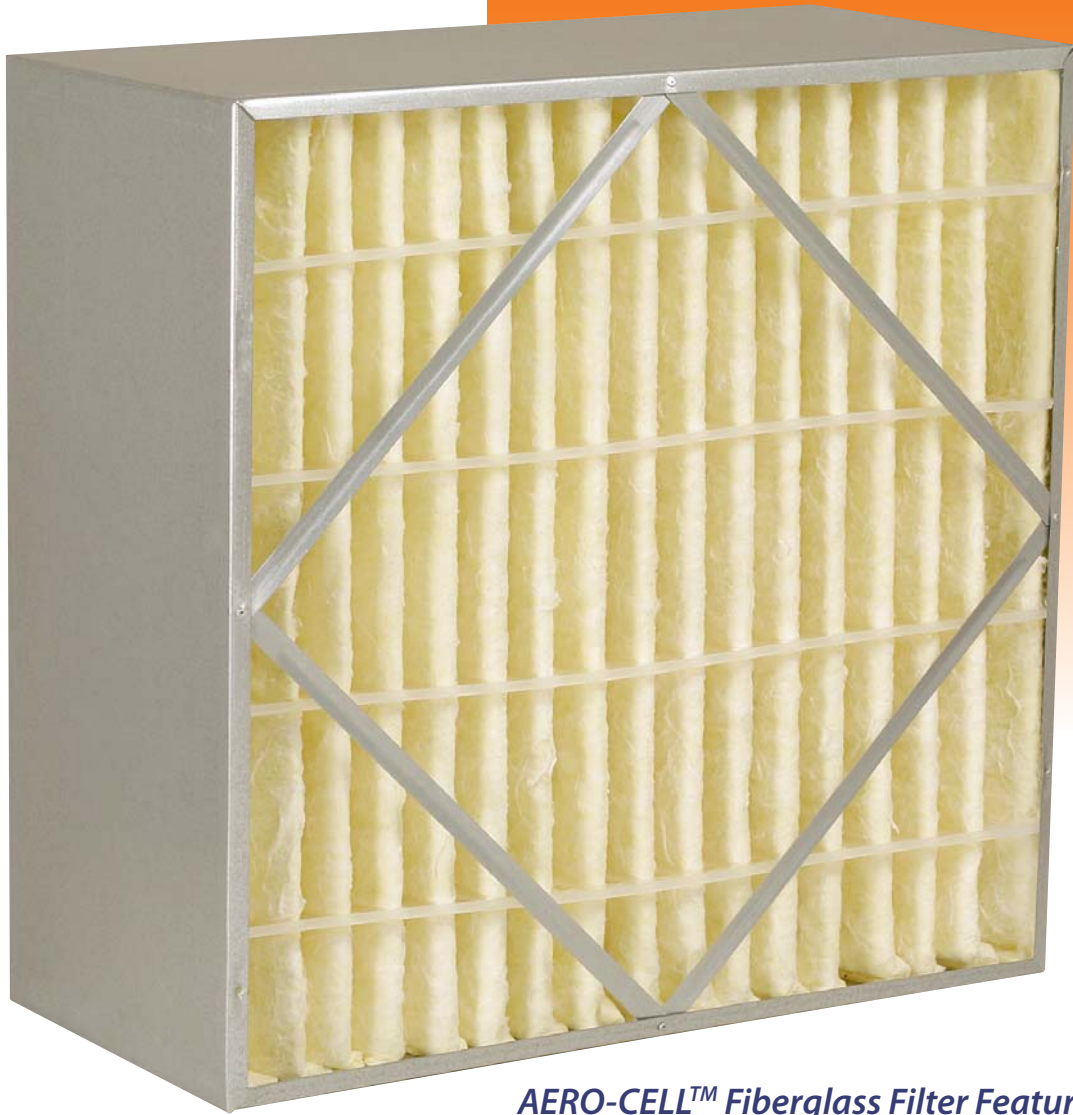

AERO-CELL™

High-Efficiency Fiberglass Rigid Air Filter



AERO-CELL™ Fiberglass Filter Features:

- **High Density, Ultra-Fine Glass Filter Media
In Class 1 and Class 2 Configurations**
- **Up To MERV 14 Performance**
- **Corrosion-Resistant Galvanized Steel**
- **Rigid Internal Support**

AERO-CELL™

High-Efficiency Fiberglass Rigid Air Filter

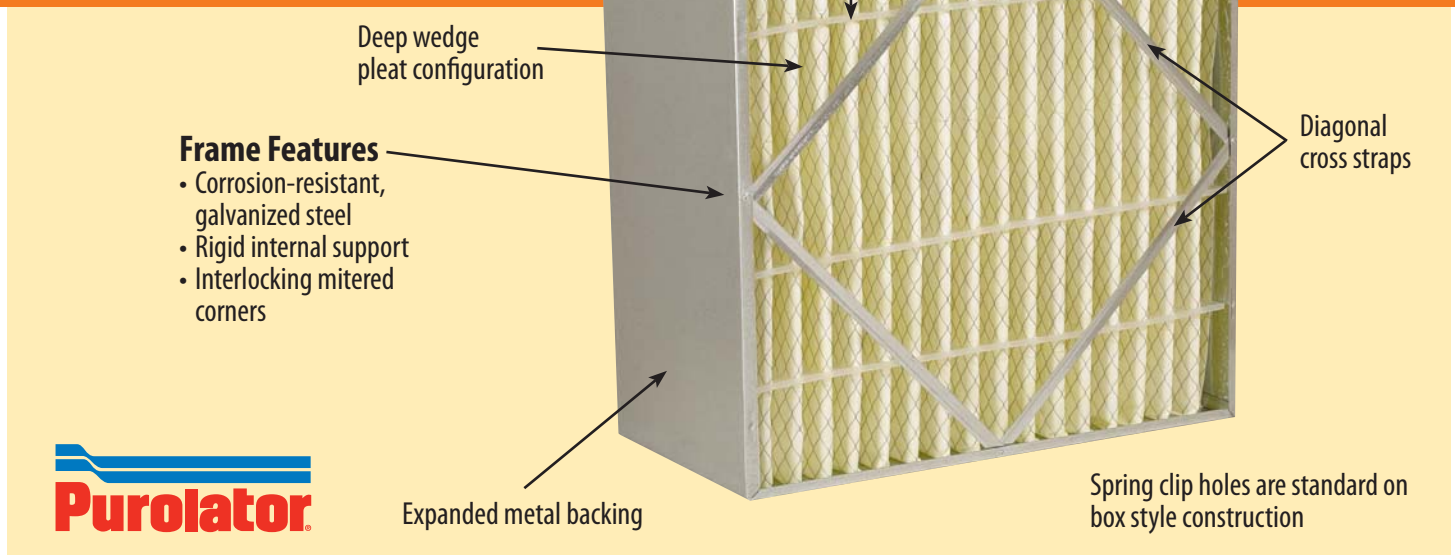

The AERO-CELL™ is a rigid air filter engineered to provide medium and high-efficiency filtration combined with a prolonged life cycle. Its box filter construction eliminates the need for retainers and special external wire media supports. A high surface area-to-depth ratio provides the maximum amount of effective filter media in areas of minimum in-line duct space. The result: A rigid, stable filter with consistent performance in a variety of operating conditions.

Frame Construction

The AERO-CELL™ perimeter frame is constructed of high strength, corrosion-resistant, galvanized steel. To prevent air bypass, the filter pak is sealed to the frame on all sides. Filter integrity is maintained by pleat stabilizers which are bonded to both the air entry and air exit sides of the pak.

Media and Backing

Each Purolator AERO-CELL™ filter utilizes a high-density filter media composed of ultra-fine glass fibers laminated to reinforced, high-strength nylon backing. The media is continuously bonded to expanded, corrosion-resistant, electro-galvanized steel which allows a 95% open face area.

Fire Resistant Construction

Each AERO-CELL™ filter is constructed to meet Underwriters Laboratories, Inc. requirements for Class 2 air filters. Class 1 model also available where required.

Pleat Configuration

To achieve a maximum dust holding capacity while minimizing pressure loss and replacement frequencies, the AERO-CELL™ incorporates aerodynamically wedge-shaped pleats into its design. The expanded metal backing and stationary pleat spacers allow consistent pleat configuration.

Applications

The AERO-CELL™ is capable of withstanding 7.0" w.g. pressure drops without noticeable media-pak deterioration, and will operate to a final resistance of 1.5" w.g. Available in a variety of filtering efficiencies and sizes, the AERO-CELL™ will satisfy and effectively service most applications.

In Variable Air Volume (VAV) applications, the AERO-CELL™ maintains consistent filtering performance throughout a full range of velocities.

Interchangeable

The AERO-CELL™ filter is designed to be completely interchangeable with all makes and types of medium to high-efficiency rigid cell filters. When used with Purolator conversion filter clips, existing side access and built-up filter banks are easily converted to support the AERO-CELL™.

In high dust concentration applications, the life of an AERO-CELL™ is extended by the use of a prefilter. The Purolator MARK 80-D® and Hi-E 40™ pleated filters have proven effective in such situations.

Product Specification

Air filters shall be the high-efficiency, deep-pleated, disposable, rigid-cell type. The filter media shall be a high loft blanket composed of randomly oriented ultra-fine glass fibers laminated to a non-woven backing.

Each filter shall have a rated airflow of ____ cfm, and initial resistance not to exceed ____, and a final resistance of ____ w.g. Each filter shall have no less than ____ square feet of media area.

The filter media shall be continuously bonded to a heavy-duty, 28-gauge, corrosion-resistant, electrogalvanized steel, expanded metal grid with an open face area of not less than 95%.

To inhibit dirty air bypas, the media grid assembly shall be bonded to all interior surfaces of the enclosure frame. The support grid shall be formed into a wedge

configuration to optimize usage of the filter media. Pleat spacers shall be permanently installed.

The enclosure frame shall be constructed of corrosion-resistant galvanized steel in such a manner as to produce a rigid, durable filter. The filter shall be the AERO-CELL™ as manufactured by Purolator Air Filtration. Filters shall be listed and rated by Underwriters laboratories, Inc. as Class 2.

Prefilters

Prefilters shall be the 2" or 4" medium efficiency (25 - 30%) pleated, disposable type, constructed with a non-woven cotton media supported by an expanded metal support backing and enclosed in a heavy duty, high wet strength board frame. The filter shall be the MARK 80-D° or Hi-E 40™ type as manufactured by Purolator Air Filtration.

Holding Frames

Holding frames shall be constructed of heavy duty, 16-gauge galvanized steel with flush-mitered, welded corners. The frame shall be supplied with closed cell eps/polyethyl/butyl gasket secured to the rear seating flanges of the frame. Each frame shall be supplied with positive sealing filter locks. The holding frames shall be the PURO® Frame type manufactured by Purolator Air Filtration.

Side Access Housings

Housing shall be side-servicing from either end through access doors fitted with positive pressure trip lock latches and gasketed inside doors, parallel to the filter track. Housings shall be constructed of heavy duty 16-gauge galvanized steel. The housing shall be equipped with both a 2" prefilter track and a 1" final filter track. Each track shall be constructed of extruded aluminum combined with reinforced nylon pile air seals to create a corrosion-resistant, air-tight seal.

Dimensions: Standard or Headered Filter Models

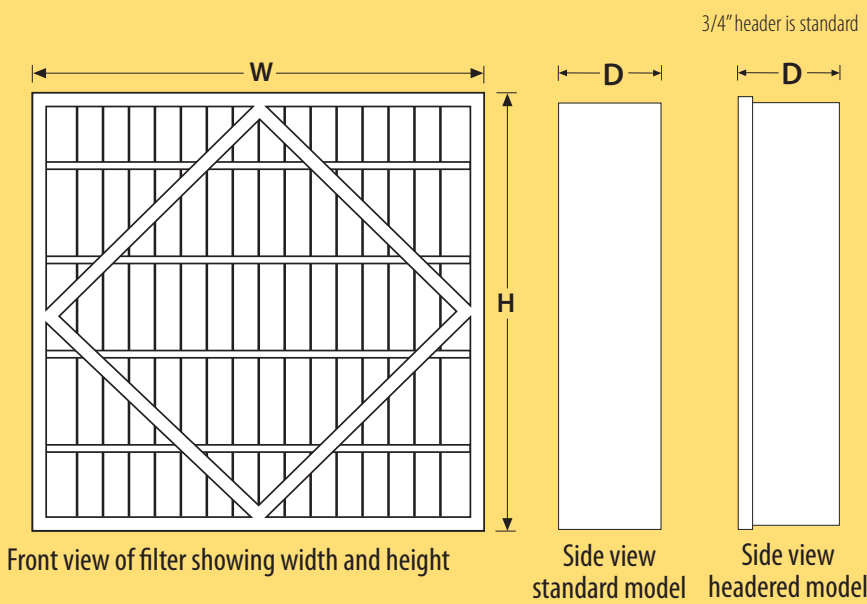

Size	Width	Height	Depth
12" x 24"	11-3/8"	23-3/8"	5-7/8" or 11-1/2"
20" x 24"	19-3/8"	23-3/8"	5-7/8" or 11-1/2"
24" x 24"	23-3/8"	23-3/8"	5-7/8" or 11-1/2"

*Optional 1-1/8" header is available upon request

AERO-CELL™

High-Efficiency Fiberglass Rigid Air Filter

Standard Models						Headered Models*		
Series	AERO-CELL™ Model Number	Nominal Size W x H x D	CFM Capacity	Resist in w.g.	Media area Sq. Ft.	AERO-CELL™ Model Number	Resist in w.g.	Media area Sq. Ft.
50%	AC50	24x24x12	2000	.35	58	HAC50	.43	47
	AC50	20x24x12	1700	.35	47	HAC50	.43	40
	AC50	12x24x12	1000	.35	28	HAC50	.43	23
	AC50	24x24x6	1000	.35	30	HAC50	.43	27
	AC50	20x24x6	850	.35	20	HAC50	.43	17
	AC50	12x24x6	500	.35	15	HAC50	.43	13
65%	AC60	24x24x12	2000	.40	58	HAC60	.48	47
	AC60	20x24x12	1700	.40	47	HAC60	.48	40
	AC60	12x24x12	1000	.40	28	HAC60	.48	23
	AC60	24x24x6	1000	.40	30	HAC60	.48	27
	AC60	20x24x6	850	.40	20	HAC60	.48	17
	AC60	12x24x6	500	.40	15	HAC60	.48	13
85%	AC85	24x24x12	2000	.62	58	HAC85	.70	47
	AC85	20x24x12	1700	.62	47	HAC85	.70	40
	AC85	12x24x12	1000	.62	28	HAC85	.70	23
	AC85	24x24x6	1000	.62	30	HAC85	.70	27
	AC85	20x24x6	850	.62	20	HAC85	.70	17
	AC85	12x24x6	500	.62	15	HAC85	.70	13
95%	AC95	24x24x12	2000	.72	58	HAC95	.80	47
	AC95	20x24x12	1700	.72	47	HAC95	.80	40
	AC95	12x24x12	1000	.72	28	HAC95	.80	23
	AC95	24x24x6	1000	.72	30	HAC95	.80	27
	AC95	20x24x6	850	.72	20	HAC95	.80	17
	AC95	12x24x6	500	.72	15	HAC95	.80	13

* Standard Header is 3/4"; a 1-1/8" header is available.
The following non-standard size is available upon request: 20x20x12
Class 1 available where required.

* Filters tested per ASHRAE standard 52.2-2007. Data based on 24x24x12
filters tested at 492 FPM.

Filtering Efficiencies

Model	Average Arrestance	MERV Perf.	Media Color
50	96%	10	Yellow
65	97%	11	Orange
85	98%	13	Pink
95	99%	14	Yellow

P-AERO-1208



www.purolatorair.com



CLARCOR Air Filtration Products
100 River Ridge Circle • Jeffersonville, IN 47130
Customer Service Team: 1-866-925-2247 • Fax: 1-800-784-3458
Email: info@purolatorair.com • www.purolatorair.com

Distributed by:

© 2008 CLARCOR Air Filtration Products.
CLARCOR Air Filtration Products has a policy of continuous product research and development and reserves the right to change design and specifications without notice. Terms and Condition of Sale can be accessed in the "LOGIN" section at www.purolatorair.com